

Lexan* 9030 Sheet

Product Datasheet

Description

Lexan* 9030 sheet is the standard grade of Lexan sheet without UV protected nor Mar resistant surface treatment. Lexan 9030 sheet combines high impact and temperature resistance with optical clarity and can be utilized for secondary glazing behind existing glazing for economical protection against breakage or intrusion. Lexan 9030 sheet can be cut, sawn, drill, milling and bent easily using standard workshop equipment without the risk of cracking and breakage and is therefore an excellent candidate for fabricating a wide range of indoor applications such as machine guards etc. Lexan 9030 sheet can be easily thermoformed into complex parts while retaining its excellent properties necessary for demanding applications such as vandal proof street furniture. Lexan 9030 sheet may be decorated using a wide variety of modern techniques such as painting and screen printing.

Typical Property Values ♦

Property	Test Method	Unit	Value
Physical			
Density	ISO 1183	g/cm ³	1.2
Water absorption, 24 hours	ISO 62	mg.	10
Water absorption, saturation /23°C	ISO 62	%	0.35
Mould shrinkage	ASTM-D955	%	0.6-0.8
Poisson's ratio	ASTM-D638	-	0.38
Mechanical			
Tensile stress at yield 50 mm/min	ISO 527	MPa	60
Tensile stress at break 50 mm/min	ISO 527	MPa	70
Tensile strain at yield 50 mm/min	ISO 527	%	6
Tensile strain at break 50 mm/min	ISO 527	%	120
Tensile modulus 1 mm/min	ISO 527	MPa	2350
Flexural stress at yield 2 mm/min	ISO 178	MPa	90
Flexural modulus 2 mm/min	ISO 178	MPa	2300
Hardness H358/30 95	ISO 2039/1	MPa	95
Impact			
Charpy impact, notched	ISO 179/2C	kJ/m ²	35
Izod impact, unnotched 23°C	ISO 180/1U	kJ/m ²	NB
Izod impact, unnotched -30°C	ISO 180/1U	kJ/m ²	NB
Izod impact, notched 23°C	ISO 180/1A	kJ/m ²	65
Izod impact, notched -30°C	ISO 180/1A	kJ/m ²	10

♦ These property values have been derived from Lexan* resin data for the material used to produce this sheet product. These property values may differ for color grades. These typical values are not intended for specification purposes. If minimum certifiable properties are required please contact your local GE- Plastics, Specialty Film & Sheet representative. All values are measured at least after 48 hours storage at 23°C/50% relative humidity. All properties are measured on injection molded samples. All samples are prepared according ISO 294.

* Lexan is a trademark of General Electric Company.



Lexan* 9030 Sheet

Product Datasheet

Typical Property Values (continued)◆

Property	Test Method	Unit	Value
Thermal			
Vicat B/120	ISO 306	°C	145
HDT/Ae, 1.8 MPa edgew. 120*1*04/s=100	ISO 75	°C	127
Thermal conductivity	DIN52612	W/m.°C	0.2
Coef.of Lin.Therm.Exp.extr. 23-80°C	DIN53752	1/°C	7.00E-05
Ball pressure test 125 ±2°C	IEC335-1	-	Passes
Thermal Index. Electrical Properties	UL746B	°C	100
Thermal Index. Mech. prop.with impact	UL746B	°C	100
Thermal Index. Mech.prop.w/o impact	UL746B	°C	100
Electrical			
Volume Resistivity	IEC93	Ohm.cm	1015
Relative Permittivity 50Hz	IEC250	-	3
Dissipation Factor 1Mhz	IEC250	-	2.9
Dissipation Factor 5Hz	IEC250	-	0.0009
Dissipation Factor 1 Mhz	IEC250	-	0.01
Arc Resistance Tungsten	ASTM-D495	sec.	119
Optical			
Light transmission ¹⁾ 3 mm	ASTM-D1003	%	89

◆ These property values have been derived from Lexan* resin data for the material used to produce this sheet product. These property values may differ for color grades. These typical values are not intended for specification purposes. If minimum certifiable properties are required please contact your local GE -Plastics, Specialty Film & Sheet representative. All values are measured at least after 48 hours storage at 23°C/50% relative humidity. All properties are measured on injection molded samples. All samples are prepared according ISO 294.

¹⁾ Light transmission value may vary by + or - 5%.

* Lexan is a trademark of General Electric Company.





Lexan* 9030 Sheet

Product Datasheet

Sound reduction

Installing Lexan 9030 sheet as secondary glazing behind glass meets the acoustic requirements of today's glazing.

Acoustic insulation DIN 52210 - 75 Rw (Db)

Lexan 9030 thickness	Air space in mm	Glass	Rw in Db
4 mm	85	6 mm	39
5 mm	85	6 mm	40
6 mm	85	6 mm	42
8 mm	85	6 mm	44

Thermal Insulation

When using Lexan 9030 sheet in combination as secondary glazing behind glass considerable energy savings can be achieved.

K-Values

Lexan 9030 thickness	Air space in mm	Glass	K-Value in W/m ² K
4 mm	20-60	4 mm	2.77
5 mm	20-60	4 mm	2.73
6 mm	20-60	4 mm	2.72

Steel ball impact test

Norm prEN356

Lexan 9030 sheet meets the highest impact performance required by the European Norm prEN356 for security glazing. A steel ball of 4.11 kg. with a diameter of 100 mm is freely dropped from different heights onto the glazing specimen. The steel ball must impact the specimen 3 times. Lexan 9030 sheet reached the highest standard required by the test at a thickness of 5 mm and above.

Category of resistance	Drop Height mm	Total number of strikes	Code designation for category of resistance	Impact energy per stroke
P1A	1500	3 in a triangle	EN 356 P1A	62 Joule
P2A	3000	3 in a triangle	EN 356 P2A	123 Joule
P3A	6000	3 in a triangle	EN 356 P3A	247 Joule
P4A	9000	3 in a triangle	EN 356 P4A	370 Joule
P5A	9000	3 x 3 in a triangle	EN 356 P5A	370 Joule

Classification table for the resistance of security glazing products according to European Norm prEN356

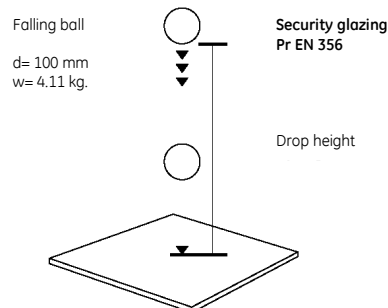

Glazing guidelines

Thermal expansion allowance

When installing Lexan 9030 sheet in a frame care should be taken to allow free expansion of the sheet. In general: Thermal expansion of the sheet is approximately 3 mm per linear meter.

Internal overglazing

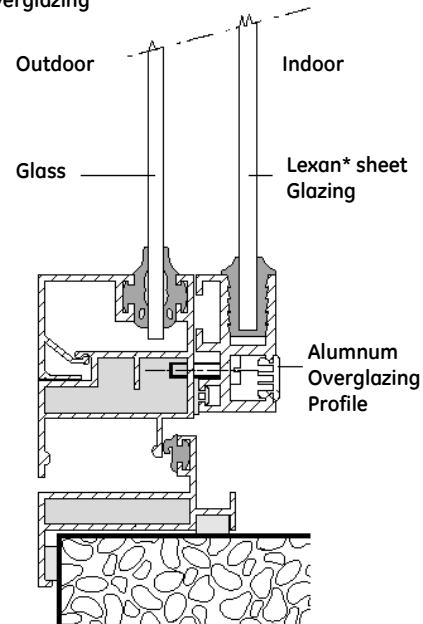

Sheet edge engagement

The required sheet edge engagement of Lexan 9030 sheet the glazing profiles is around 20 mm

Gaskets/Sealants

When using glazing compounds it is essential that the compound accepts thermal expansion movements and that compatible with Lexan 9030 sheet.

Silicone sealants and Neoprene, EPT or EPDM Rubber gaskets (65 shore) are generally recommended.

Thickness recommendation

Lexan 9030 sheet thickness recommendation installed as secondary glazing behind glass.

Shortest sheet side	Lexan 9030 sheet thickness
<400 mm	3 mm
<650 mm	4 mm
<900 mm	5 mm
<1200 mm	6 mm
<1400 mm	8 mm



theplasticshop.co.uk

at gilbert curry industrial plastics

telephone 0800 321 3085

GE Plastics Specialty Film & Sheet

Lexan* 9030 Sheet Product Datasheet

Cleaning

Small areas: wash sheet with a solution of mild soap and lukewarm water using a soft cloth or sponge.

Large areas: clean surface with a high pressure water and/ or steam cleaner.

Note: do not use abrasive cleaners or detergents or sharp instruments which may scratch the sheet.

Forming, fabricating, finishing

Cutting, drilling and milling

Circular saws, band saws, jig saws and common hacksaws, all with fine toothed panel blades, can be used for trouble free cutting of Lexan* 9030 sheet. Standard high speed steel twist drill or carbide tipped drills can be used for drilling holes in Lexan 9030 sheet. Lexan 9030 sheet can be machined using conventional milling machines fitted with standard high speed knife cutting tools. During above mentioned operations the Lexan 9030 sheet must be always securely clamped to avoid rough cut edge by undesirable vibration and the masking should be left on the sheet to prevent surface damage by scratching.

Cold curving

Cold curving of Lexan 9030 sheet is acceptable for shapes having a radius of 100 times the sheet thickness or greater.

Sheet thickness	Minimum allowable radius
2 mm	200 mm
3 mm	300 mm
4 mm	400 mm
5 mm	500 mm
6 mm	600 mm
8 mm	800 mm

Cold line bending

Cold line bending of Lexan 9030 sheet as metal is possible when taking into account the following guidelines.

- Use hydraulic bent equipment
- Protective masking should be left during bending process
- Angle max. 45 degree at sheet thickness \geq 8 mm
- Angle max. 90 degree at sheet thickness $<$ 8 mm
- Use sharp bending knife
- Bending operation should be performed quickly
- Over bending is required to achieve the desired angle after stress relaxation
- Smooth and notch free edge of Lexan 9030 sheet to avoid side cracking

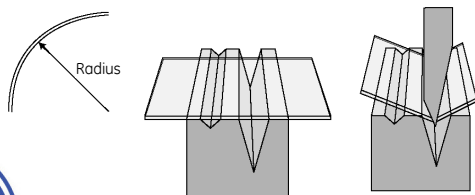

Thermoforming techniques for Lexan 9030 sheet

Vacuum forming

Lexan 9030 sheet is may be suitable to vacuum forming. It allows deep draw ratios, equal wall thickness distribution and it can be formed into complex shapes using standard thermoforming equipment which is equipped with its own sandwich type of heating devices. Lexan 9030 sheet has a formina temperature ranage of 185 - 205°C.

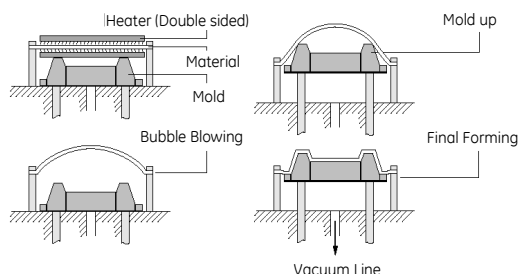

Drape forming

The process involves placing the sheet, without the masking and mould in a hot circulating oven. The temperature is raised to the point where the Lexan 9030 sheet sags (between 140 - 155°C) and conforms to the shape of the mold.

Typical drape forming set-up



Pressure forming

Pressure forming is basically the same as vacuum forming. However, during the final forming stage compressed air is applied to the positive side of the mould to force the sheet to conform more closely to the mould. The result is a component with sharp features and detailed geometry.

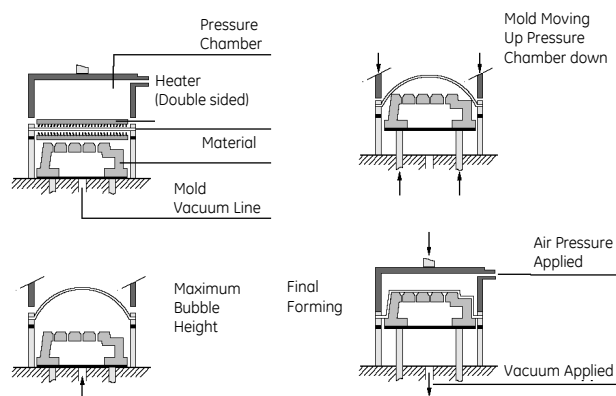



GE Plastics Specialty Film & Sheet

Lexan* 9030 Sheet Product Datasheet

Twin sheet forming

Twin sheet forming is a vacuum forming technology whereby two sheets are formed at the same time, producing an application with hollow sealed section. The connection joint between the two parts is obtained by melting of the two materials and the exposed pressure of the mould.

No additional glue or other adhesive is therefor necessary.

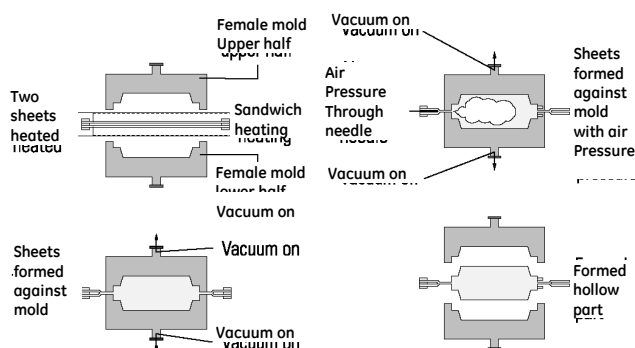

Pre-drying

It is extremely important to ensure that Lexan 9030 sheets are free of moisture prior to thermoforming. A hot circulation oven set at 120°C is recommended.

Sheet thickness	Drying time
2 mm	3 hours
3 mm	4 hours
4 mm	10 hours
5 mm	16 hours
6 mm	24 hours

Decorating

Painting

Lexan 9030 sheet can be painted without surface treatment other than cleaning. Provided certain basic recommendations are followed, most techniques used to apply paint to other material, can be used for Lexan 9030 sheet. Paint systems for Lexan 9030 sheet are readily available as standard items from various manufacturers.

Use only recommended paint

Painting systems

Supplier	Paints	Thinner	Comments
AKZO	Autocryl	-	2K Acrylic
Coatings	01-69004 Class 45	06-302007	Primer/2K/PUR Top
coat/2K/PUR			
Diegel	PA 21	24896	1K Flex. acrylic
Schaeppman	C1 F57 C1 W28	VOA 462 Water	Acrylic Acrylic/water
based			
Herberts	C4 P212 R 47633 41605	VOA421/H4P4 - 11098	2K Acrylic 2K Primer Basecoat BMW
mete			
	R4790 R4780	- -	2K Clear coat 2K One layer
system			
Becker	TH 130 DJ-331-5176 TC 132	NT19 2K ET-134 1K -	Top coat Primer (flexible) 2K Clear coat 1K Water-
HSH based	Interplan 1000		
Morton	L446	U987	1K Acrylic Syst.

NB For information regarding application techniques and property values please contact the relevant paint supplier.

Screen process printing

Screen printing is a well established process that offer a wide variety of options for a decorative finish. Approved Lexan 9030 sheet screen paints, when applied to flat, uniformed sheet are handled in the same manner as screen paints fit other plastic material.

Silk Screen Inks

Supplier	Inks
Sericol	Seritex TH Polyplast PY Plastipure PP
Wiederhold	HG/PK/PK-Jet
Visprox	TCI 8700/STR 5700/TCP 9900
Diegel	HV/Z
Gibbon Inks & Coating Ltd.	Matercryl Polyvin/Marlerstyrene
Coates	Vynaglaze/Vynafresh/Touchkey
Pröll	Jet 200/Thermo-Jet/Noriprint PS
Marabu	Marastar SR/Maraplast D

Anti static treatment/cleaning

Lexan 9030 sheet tends to build up a static charge. It is often necessary to clean and discharge surface prior to painting and screen printing. Special anti static formulations are available which reduce the static charge. Cleaning prior to thermoforming Lexan 9030 sheet it is recommended that dust is blown off with unionizing air.

Anti-static Products

Company/Supplier	Product/Brand Name
American Cyanamid Co.	Cyastat SN50
AKZO Chemicals	No. 03643
Morton	S154





theplasticshop.co.uk

at gilbert curry industrial plastics

telephone 0800 321 3085

GE Plastics Specialty Film & Sheet

Lexan* 9030 Sheet Product Datasheet

Fire performance

Lexan 9030 sheet has good fire behavior characteristics. Lexan sheet does not contribute significantly to the spread of fire or to the generation of toxic gases.

For details please contact your local sales office.

Light transmission

Transparent Lexan 9030 sheet have excellent light transmission, dependent of thickness between 84 - 87%.

Product Availability •)

Product code: Lexan 9030

Standard gauge: 0.75 – 1 – 1.5 mm

Standard width: 625 x 1250, 2050x 3050 mm

Standard length: 1250 x 1250, 2050 x 6050 mm

Standard colors: transparent code 112 and opal white code 82103

Texture: blue print

Masking:

top side Coex opal white PE

bottom side Coex transparent PE

•) Other gauges and other dimensions upon request and are subject to minimum order quantities. Dimensions only for 0.75 mm

Chemical resistance

Taking into account the complexity of chemical compatibility, all chemicals which come into contact with Lexan 9030 sheet should be tested. Consult our technical service center for more technical info.

DISCLAIMER: THE MATERIALS, PRODUCTS AND SERVICES OF THE BUSINESSES MAKING UP THE PLASTICS BUSINESS UNIT OF GENERAL ELECTRIC COMPANY, ITS SUBSIDIARIES AND AFFILIATES, ARE SOLD SUBJECT TO ITS STANDARD CONDITIONS OF SALE, WHICH ARE INCLUDED IN THE APPLICABLE DISTRIBUTOR OR OTHER SALES AGREEMENT, PRINTED ON THE BACK OF ORDER ACKNOWLEDGMENTS AND INVOICES, AND AVAILABLE UPON REQUEST. ALTHOUGH ANY INFORMATION, RECOMMENDATIONS, OR ADVICE CONTAINED HEREIN IS GIVEN IN GOOD FAITH, GE'S PLASTICS BUSINESS MAKES NO WARRANTY OR GUARANTEE, EXPRESS OR IMPLIED, (i) THAT THE RESULTS DESCRIBED HEREIN WILL BE OBTAINED UNDER END-USE CONDITIONS, OR (ii) AS TO THE EFFECTIVENESS OR SAFETY OF ANY DESIGN INCORPORATING ITS PRODUCTS, MATERIALS, SERVICES, RECOMMENDATIONS OR ADVICE. EXCEPT AS PROVIDED IN GE'S PLASTICS BUSINESS' STANDARD CONDITIONS OF SALE, GE'S PLASTICS BUSINESS AND ITS REPRESENTATIVES SHALL IN NO EVENT BE RESPONSIBLE FOR ANY LOSS RESULTING FROM ANY USE OF ITS MATERIALS, PRODUCTS OR SERVICES DESCRIBED HEREIN. Each user bears full responsibility for making its own determination as to the suitability of GE's Plastics business' products, materials, services, recommendations, or advice for its own particular use. Each user must identify and perform all tests and analyses necessary to assure that its finished parts incorporating GE's Plastics business' products, materials, or services will be safe and suitable for use under end-use conditions. Nothing in this or any other document, nor any oral recommendation or advice, shall be deemed to alter, vary, supersede, or waive any provision of GE's Plastics business' Standard Conditions of Sale or this Disclaimer, unless any such modification is specifically agreed to in a writing signed by GE's Plastics business. No statement contained herein concerning a possible or suggested use of any material, product, service or design is intended, or should be construed, to grant any license under any patent or other intellectual property right of General Electric Company or any of its subsidiaries or affiliates covering such use or design, or as a recommendation for the use of such material, product, service or design in the infringement of any patent or other intellectual property right.

* Lexan is a trademark of General Electric Company

